



DBK70™ Vehicle Network Interface



Compatibility: ✓ WaveBook ✓ ZonicBook ✓ LogBook ✓ DaqBook ✓ DaqLab ✓ DaqScan ✓ DaqBoard/2000 Series

Features

- Measure up to 70* vehicle network parameters with one DBK70™
- Synchronously record vehicle network data along with analog and digital measurements made with IOtech's data acquisition systems
- Supports J1850 VPW, J1850 PWM, ISO-9141, CAN, J1939, Keyword2000
- Up to 4 network types can be attached concurrently to one DBK70
- Attaches to any of IOtech's data acquisition products
- DBK70 can also be used with any data acquisition device in a stand-alone mode



The DBK70 can easily be integrated with any of IOtech's data acquisition products

The DBK70™ vehicle network module allows IOtech's data acquisition products to record vehicle network parameters synchronously with measurements made by IOtech data acquisition systems. In contrast to other vehicle network recording systems, IOtech offers a unique solution that guarantees time correlation between vehicle network parameters and direct analog and digital measurements.

By attaching the DBK70 to the vehicle's OBD (on-board diagnostic) connector, network parameters of all kinds can be recorded along with measurements from transducers attached directly to IOtech's family of data acquisition products.

For example, when-combined with IOtech's WaveBook portable data acquisition device, up to 72 transducer or network channels can be read at up to 1 Msample/s. When attached to a DaqBoard/2000™ PCI card, up to 407 channels of analog, digital, counter/timer, and vehicle network channels can be collected at up to 200 kHz. For stand-alone applications, the DBK70 can be used with IOtech's LogBook to collect hundreds of channels of transducer data and network parameters at up to 100 kHz without the need for a PC. IOtech's solutions offer better performance than others costing significantly more.

An advantage of IOtech's unique system is the ability to display scrolling waveforms of vehicle parameters *and* transducer channels concurrently in real time. The DBK70's unique architecture facilitates synchronization by converting vehicle network messages into analog values that are then digitized by the data acquisition system. In this way, the data acquisition system can measure vehicle network parameters along with other transducer signals, synchronous to one another.

The DBK70 was designed specifically for data collection tasks, so there's no need to learn complicated in-vehicle network analysis software. The DBK70 includes a software application that provides database management and setup services. Unlike other network devices, no costly software add-ons are required.

As part of vehicle network protocol, all messages transmitted on the network carry a parameter identifier (PID). To set up the DBK70, you can enter proprietary PIDs directly into the software application or import an existing PID database. The software is delivered with a database of more than 600 PIDs. After the PIDs are entered, simply select the messages of interest, set the de-

sired sample rates, and download the configuration into the DBK70's nonvolatile memory via its serial configuration port.

The DBK70 has four internal slots into which parameter-capture cards (DBK70-P4) can be installed. Each capture card adds 4 vehicle parameters that can be monitored, for a total of 16 parameters for each DBK70 (see PidPRO software for monitoring up to 70 channels).

One DBK70 can be connected to up to four different networks concurrently. The DBK70's multiple network interface allows the flexibility to use one device on multiple vehicle platforms, or to concurrently collect data from multiple networks on a single vehicle. Internal interface slots allow up to four network modules to be inserted.



The CA-210 network cable provides the DBK70 with vehicle bus data

* See PidPRO software section

† CE pending



DBK70™

Example Applications

Brake Performance Testing

While a DaqBook® data acquisition system directly measures thermocouples, strain gages, and accelerometers, the DBK70 can provide important vehicle network parameters such as speed and RPM. Using the DBK70 to monitor vehicle parameters eliminates the need to connect redundant transducers and measurement equipment.

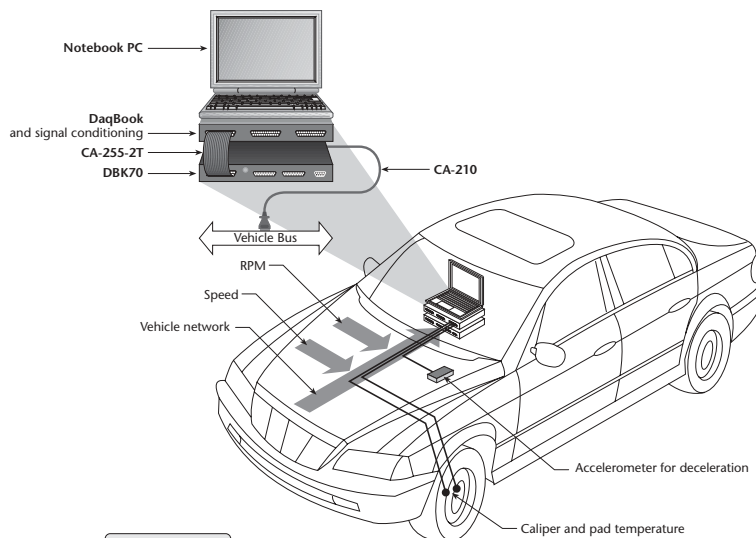

Dynamometer Emissions Testing

When used with the DaqBoard™ data acquisition plug-in card, the DBK70 can enhance emissions testing by providing vital parameters including engine temperature, fuel consumption, and air/fuel ratio. Multiple exhaust temperatures can be monitored directly using thermocouples or RTDs.

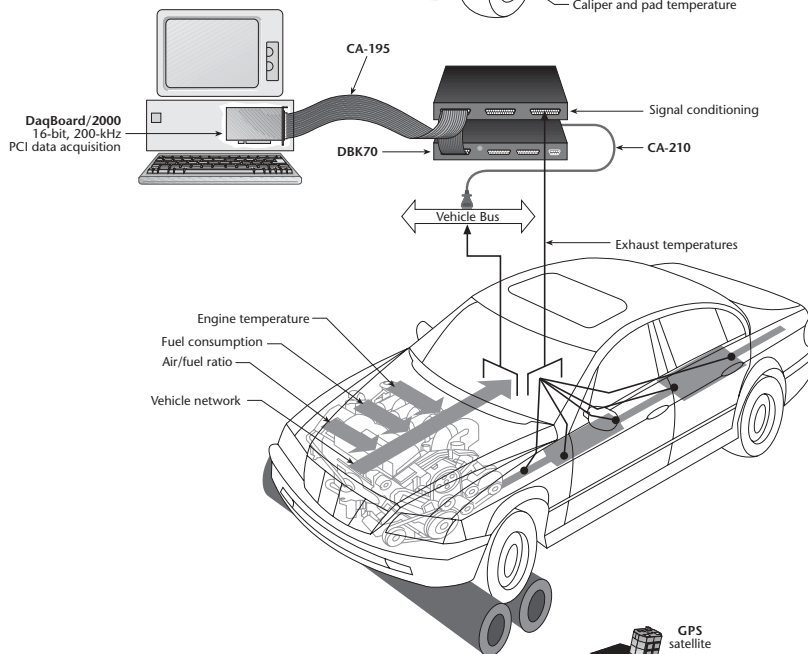

Test Track Suspension Testing

The LogBook™ stand-alone data acquisition system collects data into its internal PC-Card memory without requiring an attached PC. Using the LogBook's accelerometer signal conditioning module, vibration and shock can be measured while synchronously capturing speed and RPM from the vehicle network using the DBK70. The LogBook/360™ can also synchronously collect location information from any GPS receiver, allowing vibration data to be correlated to track position. In addition, acquired data can be accessed remotely via a cellular modem attached to the LogBook.

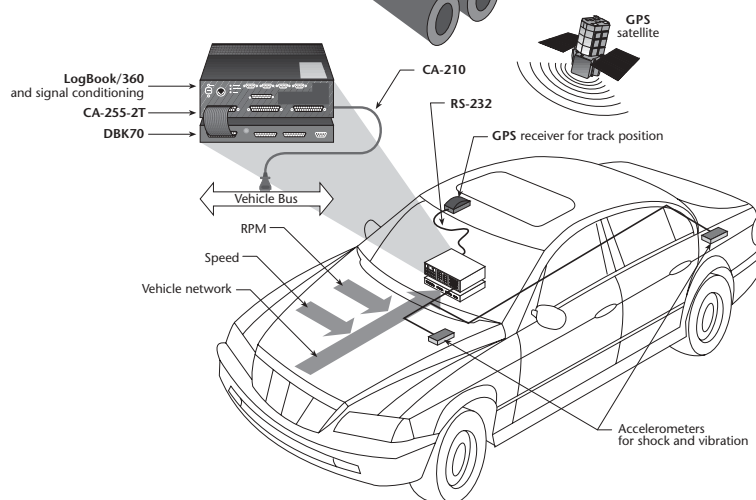



DBK70™

Example Applications

Engine Performance Testing

Using the LogBook with signal conditioning, the DBK70, and a GPS receiver, engine performance relative to altitude, speed, throttle, and engine temperatures can be captured — all without a PC attached.

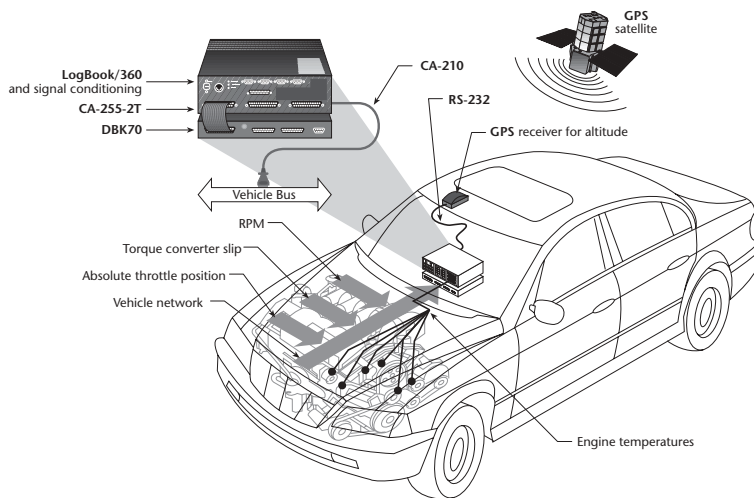

Noise/Vibration/Harshness (NVH)

Using a WaveBook™ to monitor accelerometers and microphones along with a DBK70 to record speed, gear, and RPM information from the vehicle network, the PC can show real-time waveforms correlating all of the collected parameters, plus real-time storage to disk.

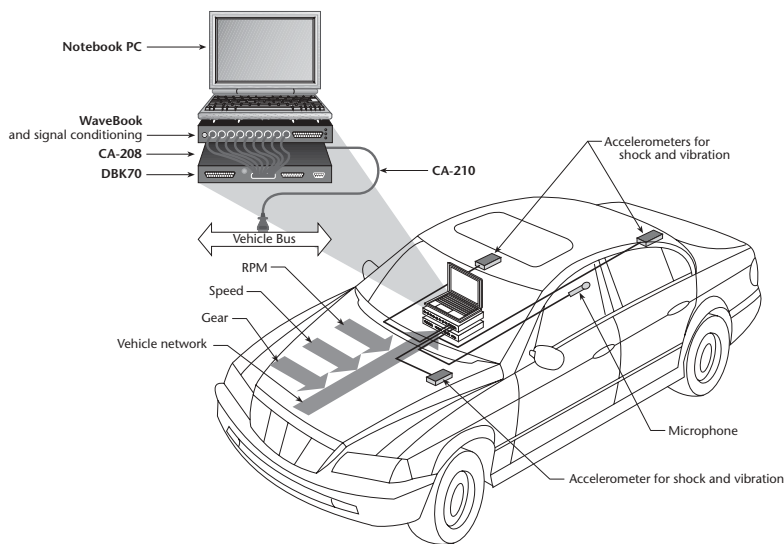

Cabin Comfort

To monitor passenger comfort and usage patterns, a DaqBook and DBK70 can be combined to measure cabin temperatures, shock and vibration, sound, door, and window states.

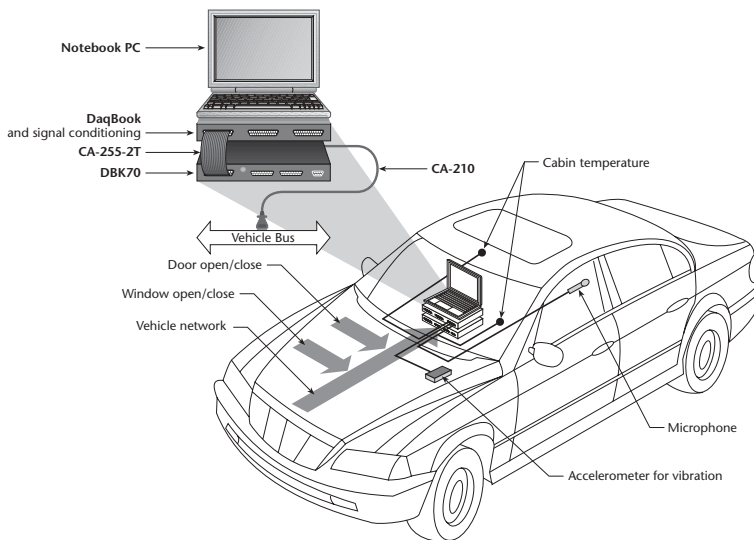



DBK70™

General Information

Portable Data Acquisition Products

IOtech's data acquisition products, to which the DBK70 attaches, are capable of collecting data from a wide variety of inputs including low and high voltages, currents, thermocouples, RTDs, accelerometers, strain gages, bridge devices, pulse train sources, and digital signals.

Out-of-the-Box™ software, included with most IOtech products, combines an easy-to-use interface with a powerful set of features that include hardware setup, trigger definition, real-time indicators like scroll charts and bar graphs, sample rate setup, direct-to-disk acquisition, and data format conversion for popular analysis packages like DIAdem®, DASyLab®, DADiSP™, MATLAB™, and Excel. Also included is eZ-PostView™, an extensible, full-featured post-acquisition waveform display and inspection package.

PidPRO™ Software

Included free with each DBK70 is PidPRO, a software application for setting up the DBK70, managing PID databases, and viewing network data. For additional functionality, the PidPRO Plus software add-on provides data logging, automatic DBK70 setup features, a network monitor, and the ability to configure up to 70 data channels through a feature called *virtual channels*.

In addition to capturing the 16 specified parameters associated with its analog outputs, the DBK70 is also capable of capturing parameters associated with up to 70 virtual output channels. Once the DBK70 outputs are configured, data from both the physical and virtual outputs are continuously streamed out the DBK70's RS-232 port. After the configuration is saved in the DBK70's non-volatile memory, the unit will power-up configured and begin sending the serial ASCII data stream. Virtual outputs provide an economical means of increasing the number of vehicle network parameters monitored. Documentation and examples are provided to capture individual channel data in DASyLab using its RS-232 function module, and LogView using the LogBook/GPS software option.

The Network Monitor feature included with the PidPRO Plus software add-on provides a means of viewing in real-time unmodified network traffic in a scrolling text window. In the monitoring window, the user can provide filtering and interactively transmit network messages while watching network messages scroll by in the text window. The monitor allows the user to passively probe the network for messages or interact as desired.

For quick configuration of all of the DBK70's output channels, PidPRO Plus includes a *Load From File* feature, which allows the user to save/load an entire DBK70 output channel configuration to/from disk. This time saving feature eliminates the need to configure each channel, one at a time.

PidPRO Plus™ Features

- Log channel values to disk in real-time
- Increase maximum channel count from 16 to 70
- Real-time network monitor
- Save/Load DBK70 channel configuration to/from disk

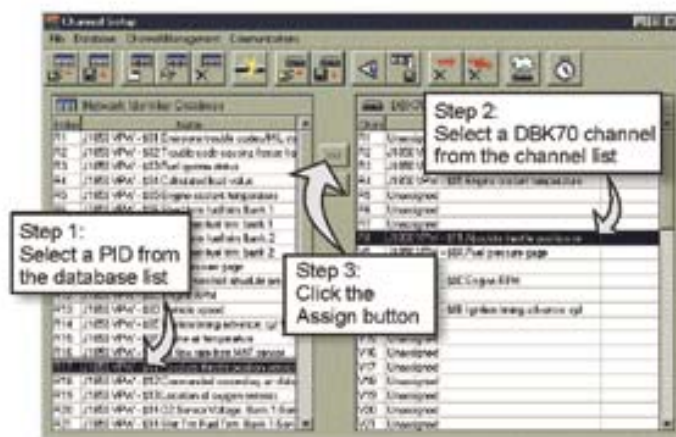

Assign a PID record to a DBK70 channel in just three steps

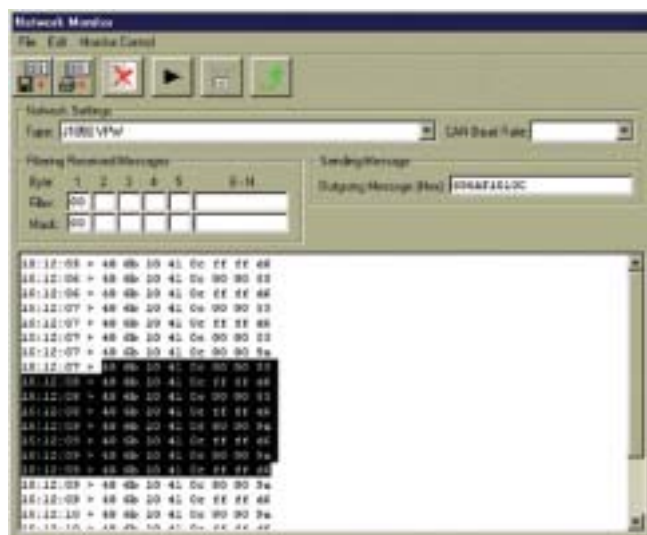

The Network Monitor window provides a means to view unmodified network traffic



DBK70™

Specifications & Ordering Information

Specifications

Dimensions: 280 mm W x 216 mm D x 44 mm H

(11" x 8.5" x 1.75")

Weight: 1.1 kg (2.5 lbs)

Operating Temperature: -20 to +70°C

Connectors:

Serial Configuration Port: DB9

Network Port: HD44

Direct Parameter Outputs: (2) DB25

Data Acquisition Cascade Port: DB37

Power: DIN5

Power Consumption: 35 mW

Supply Voltage: 10 to 30 VDC, sourced by the vehicles OBD connector or the auxiliary input; AC supply also included

Analog Output Range: 0 to 5V

Operating System: All versions of Windows®

Ordering Information

The DBK70 has eight internal slots into which configuration cards can be installed. Four slots are reserved for Network Interface cards, and four slots are for Parameter Capture cards. If only one network is to be used (such as J1850 Variable Pulse Width), then only one Network Interface card is required. If multiple networks are to be attached to one DBK70, then up to four Network Interface cards can be installed.

Each Parameter Capture card enables the simultaneous capture of up to four parameters, such as four different temperatures within the vehicle. To capture more than four parameters simultaneously, additional Parameter Capture cards can be installed. Up to four cards, or a total of 16 network parameters, can be simultaneously captured by one DBK70. If more than 16 parameters need to be captured, virtual channels can be employed.



The CA-208 is used to connect the DBK70 to a WaveBook or ZonicBook

Description

Vehicle network converter chassis, including CA-210 10 ft. OBDII connection cable, CA-212 serial port cable, AC power supply, and PidPRO

Software add-on to PidPRO

Part No.

DBK70

PidPRO Plus

Note: Contact IOtech regarding network monitoring software option.

Network Interface Cards (up to 4 per chassis)

J1850 variable pulse width

DBK70-J1850-VPW

J1850 pulse width modulated

DBK70-J1850-PWM

ISO-9141

DBK70-ISO-9141

CAN Bus

DBK70-CAN

4 parameter capture card (up to 4 in one chassis for a total of 16 measured parameters)

DBK70-P4

Accessories & Cables

Rack mount kit

RackDBK3

Required cable for attaching to WaveBook products

CA-208

Additional vehicle connection cable

CA-210

DBK70 CAN interface cable; J1939 compliant

CA-218

Shielded P1 T cable for use with DaqBook/2020, LogBook/360, and WBK40/41

CA-255-4T

Shielded P1 T cable for use with DaqBook/2001, DaqBook/2005, LogBook/300, DaqLab/2001, and DaqLab/2005

CA-255-2T

Ribbon cable for use with DaqScan

CA-37-x

Note: The CA-37-x ribbon cable can also be used in lieu of the CA-255-x molded T cables.

For complete information on accessories and cables, visit

www.iotech.com/acc

Related Products

WaveBook

p. 17

ZonicBook

p. 59

LogBook

p. 75

DaqBook

p. 89

DaqLab

p. 103

DaqScan

p. 108

DaqBoard/2000 Series

p. 192



The CA-218 provides a direct connection to truck/bus networks